

# Moduline SafeBarrier Pro Specification

## 1.5m high vertical bar type - Type 4e

### DRAWING NOTES

#### Design Scope and Compliance:

This specification covers the design of the barrier members and base fixing only, and does not cover the design of the supporting structure. The contractor or building designer must ensure that the supporting structure can support the barrier loads. Min concrete strength 20 MPa

**Description:** 1500 mm high barrier side fixed to concrete slab or concrete wall.  
**Application:** Concrete slab or concrete wall.

The barrier design complies with the New Zealand Building Code:

- Sec. B1/ VM1 (structure)
  - AS/NZS 1170.1 barrier cat. A, B, C3 & E
  - NZS3604:2011 extra high wind zone ( 55m/s).
- Section F4/AS1 (safety from falling).
- Section F9/AS1 (restricting access to residential pools)

#### Notes:

Bolts & washers shall be 316 stainless steel.  
 Provide neoprene washers or DPC between washers and posts.  
 All measurements in mm unless stated otherwise.

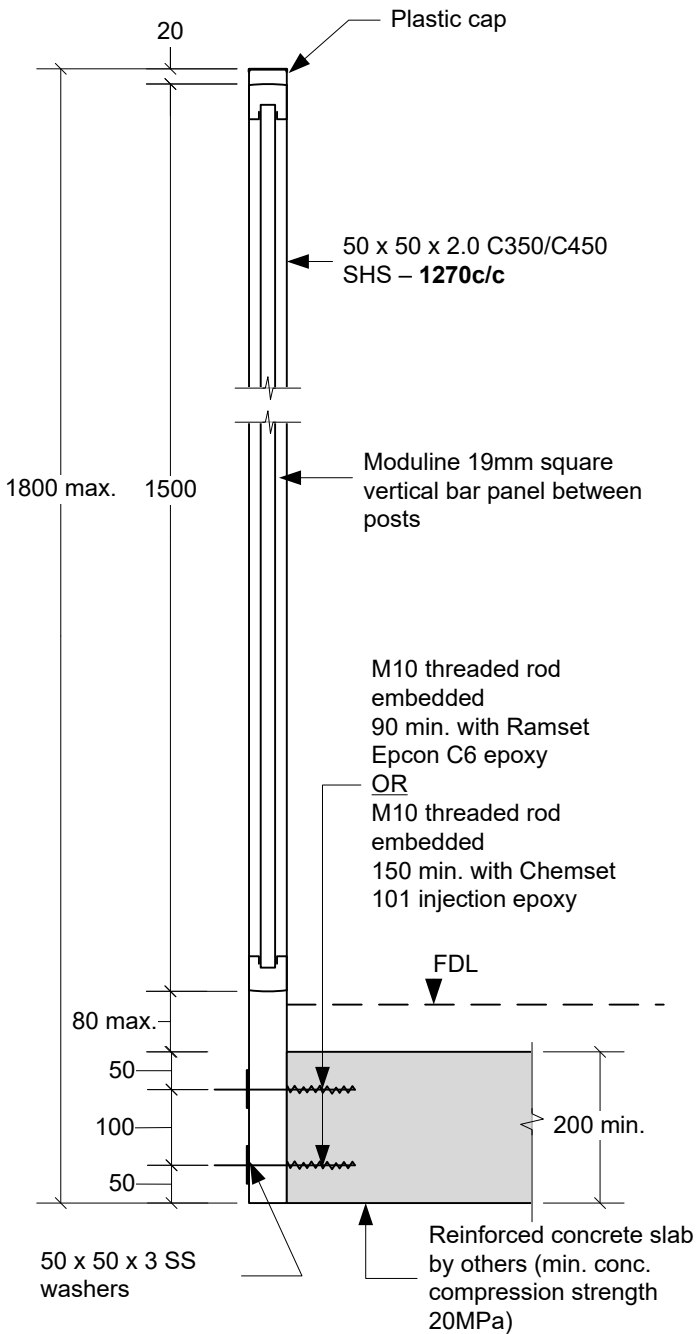

**Section 4** (Scale 1:10)

E	19/09/2024
D	04/09/2024
C	12/01/2022
B	20/09/2019
A	14/12/20017
-	30/8/2017
Revision	Date

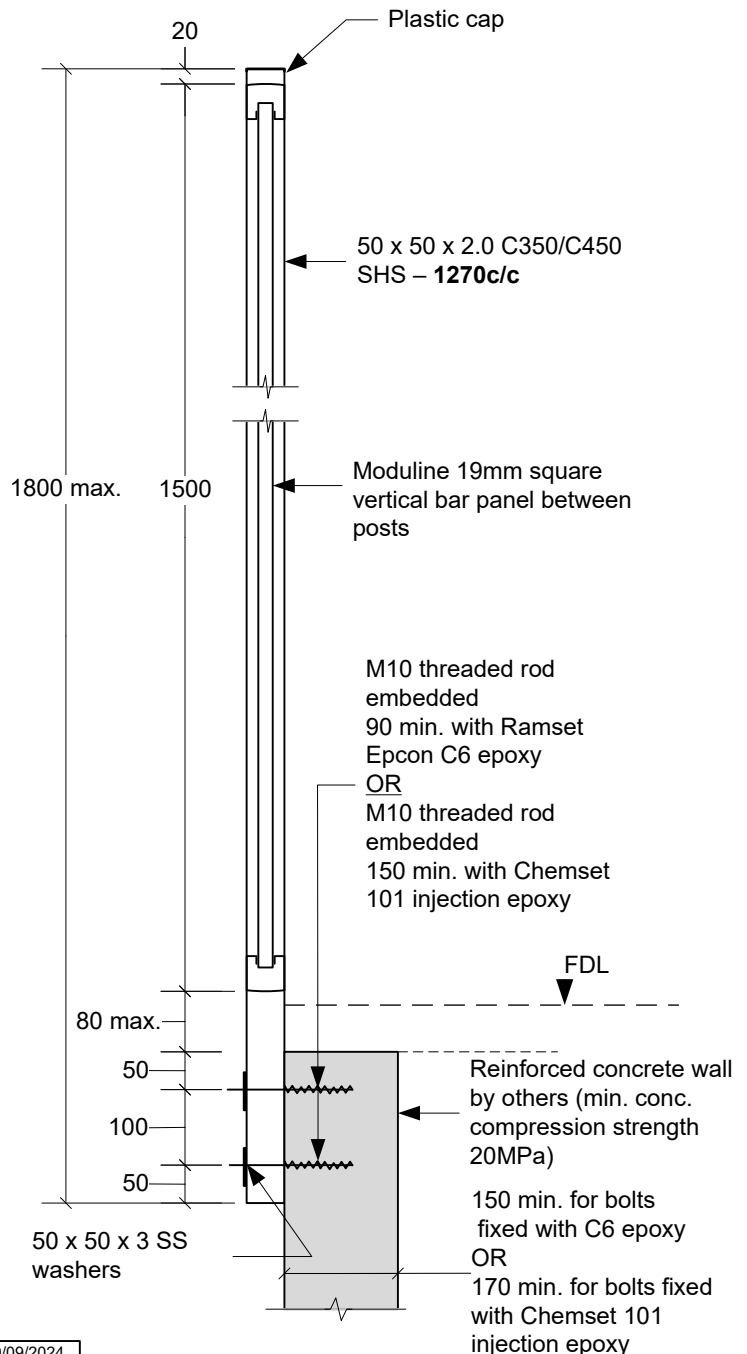

**Section 4** (Scale 1:10)

Revision	E
----------	---

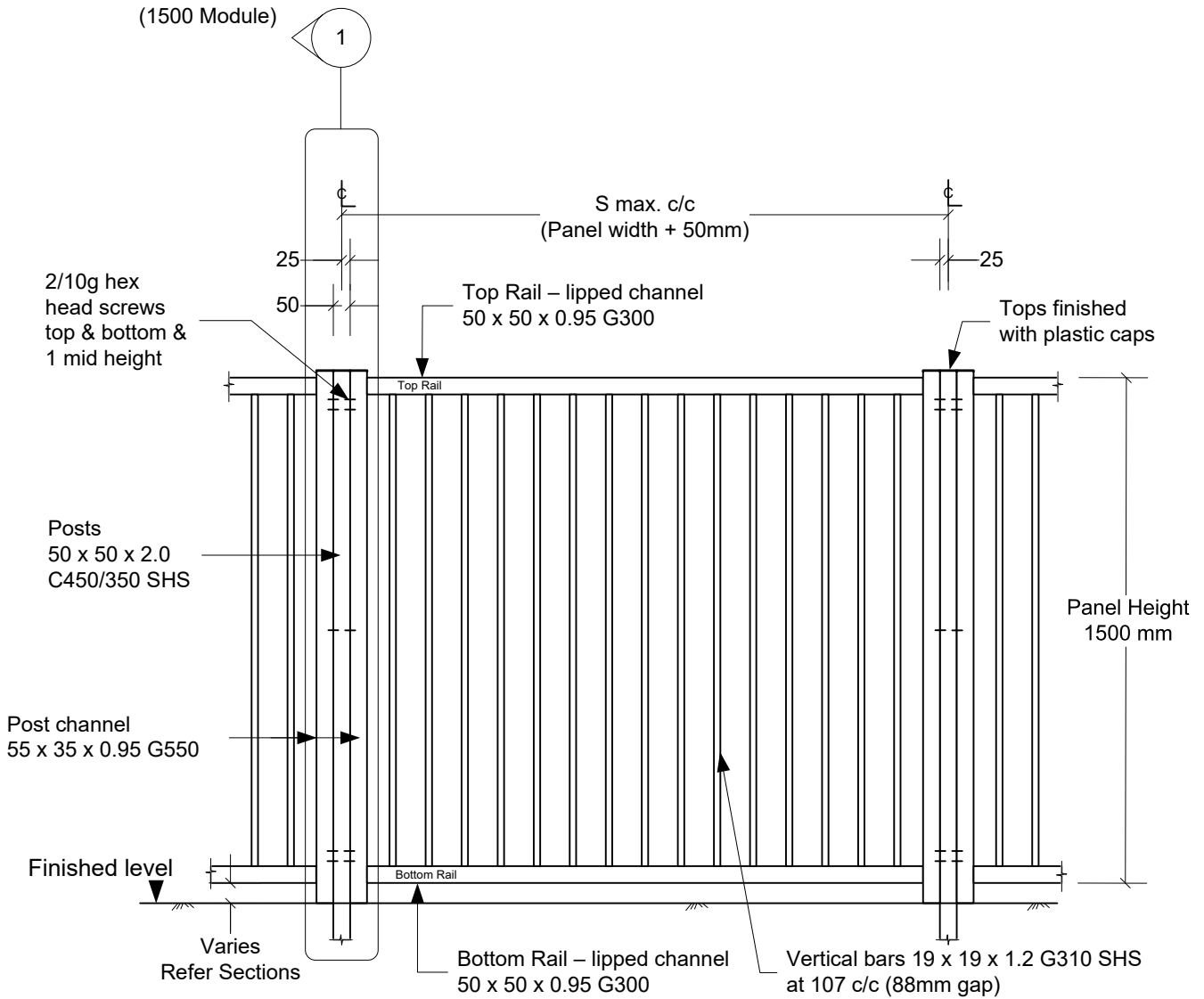

**Notes:**

All measurements in mm unless stated otherwise.

**1.5m high vertical bar type - Type 4**

(See specification sheet for detail)

(Scale 1:20)

C	04/09/2024
B	20/09/2019
A	19/01/2018
-	30/8/2017
<b>Revision</b>	<b>Date</b>

<b>Revision</b>	<b>c</b>
-----------------	----------

# Moduline SafeBarrier Pro Specification

## 1.5m high solid panel type - Type 4e

### DRAWING NOTES

Design Scope and Compliance:  
 This specification covers the design of the barrier members and base fixing only, and does not cover the design of the supporting structure.  
 The contractor or building designer must ensure that the supporting structure can support the barrier loads.  
 Min concrete strength 20 MPa

Description: 1500 mm high barrier side fixed to concrete slab or concrete wall.  
Application: Concrete slab or concrete wall.

The barrier design complies with the New Zealand Building Code:  
 Sec. B1/ VM1 (structure)  
 - AS/NZS 1170.1 barrier cat. A, B, C3 & E  
 - NZS3604:2011 high wind zone (44m/s).  
 Section F4/AS1 (safety from falling).  
 Section F9/AS1 (restricting access to residential pools)

Notes:  
 Bolts & washers shall be 316 stainless steel.  
 Provide neoprene washers or DPC between washers and posts.  
 All measurements in mm unless stated otherwise.

**Not for use in very high or extra high wind zones**

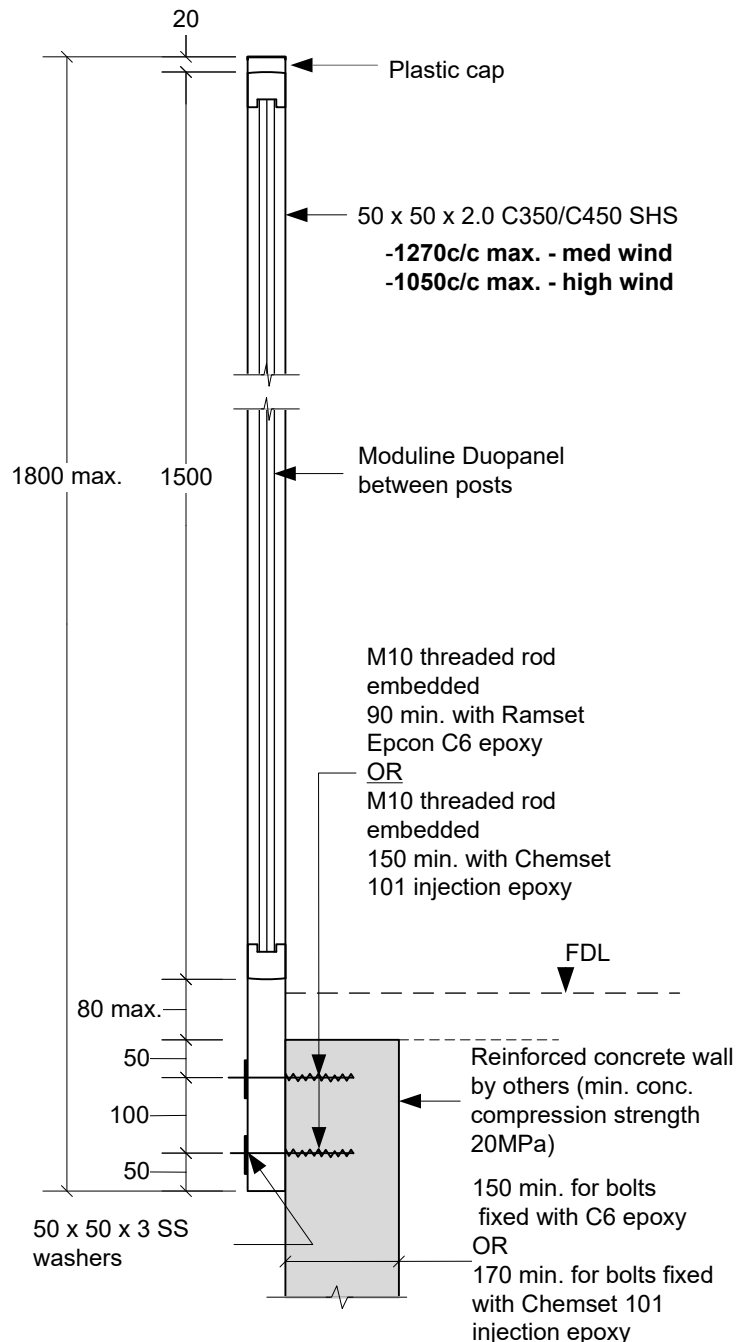
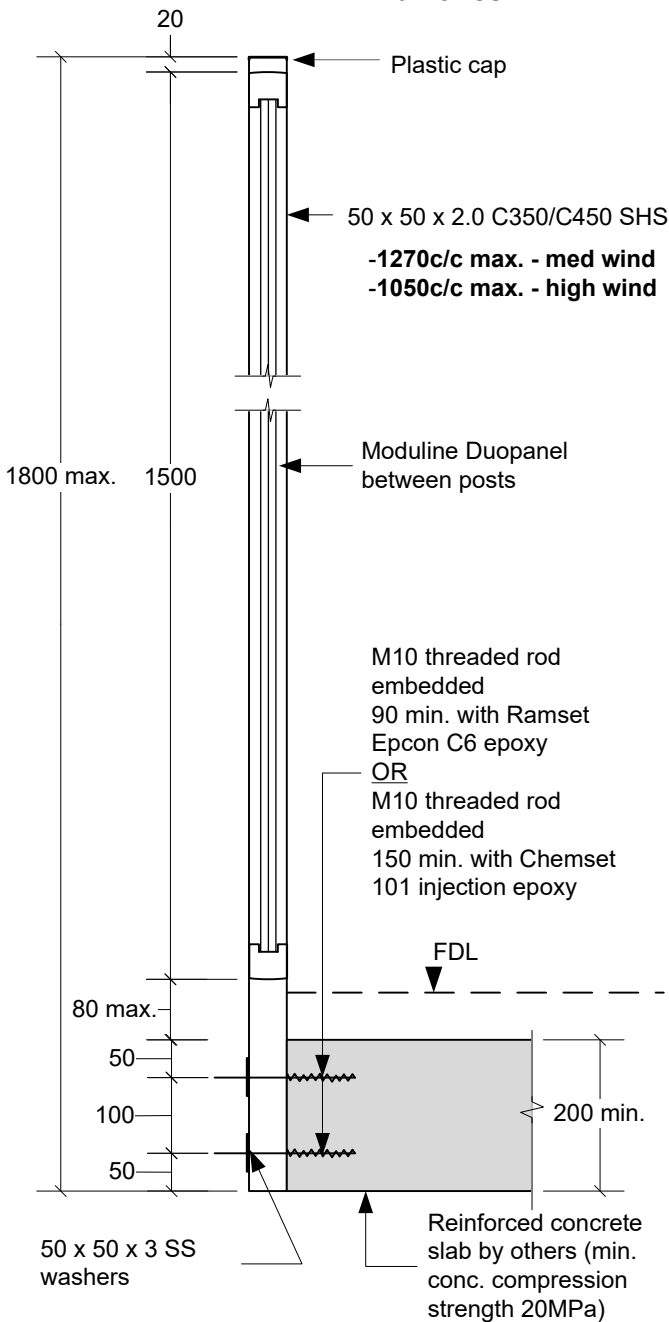

**Section 2** (Scale 1:10)

C	19/09/2024
B	04/09/2024
A	12/01/2022
-	20/09/2019
Revision	Date

**Section 2** (Scale 1:10)

Revision	C
----------	---

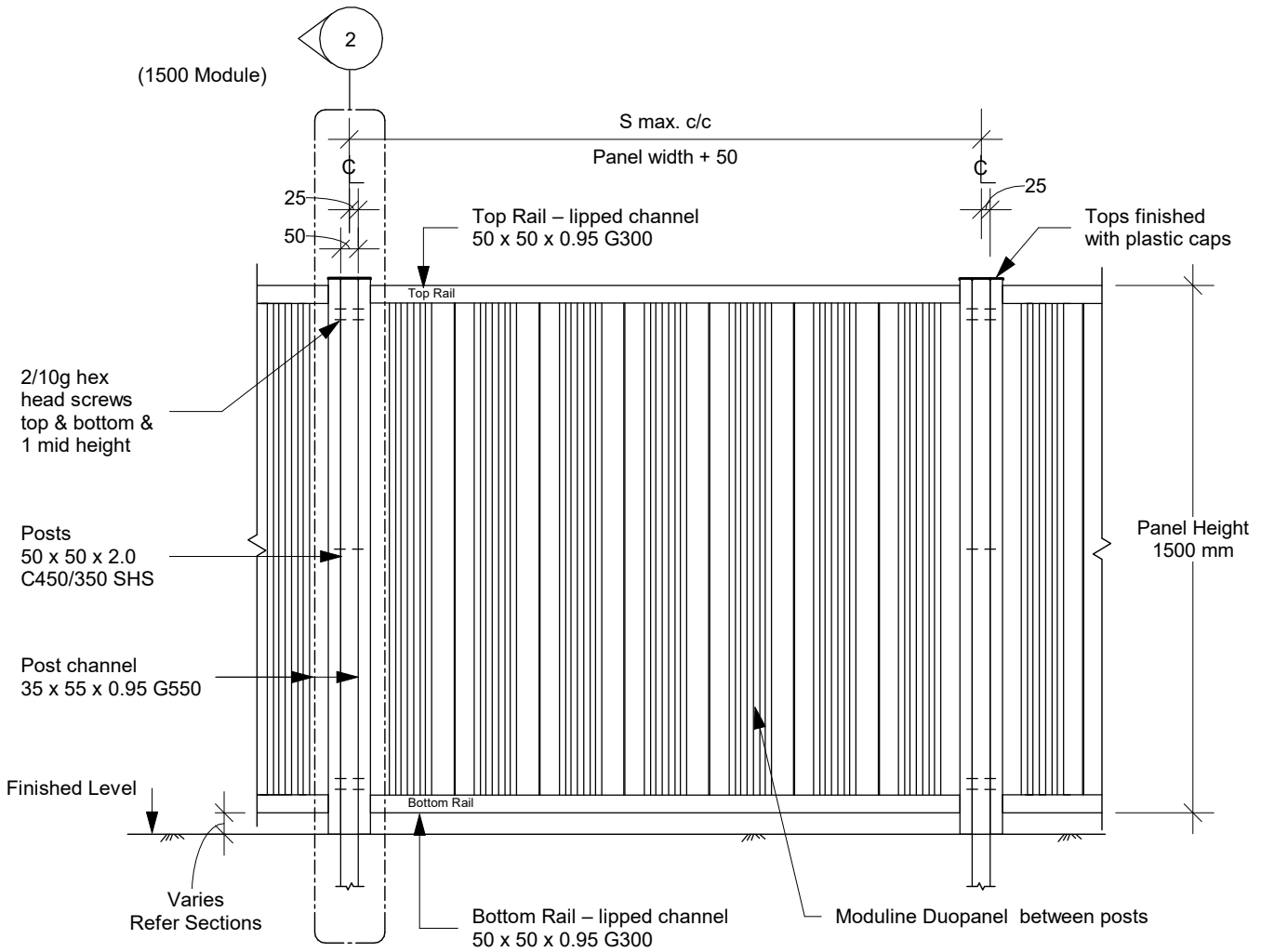
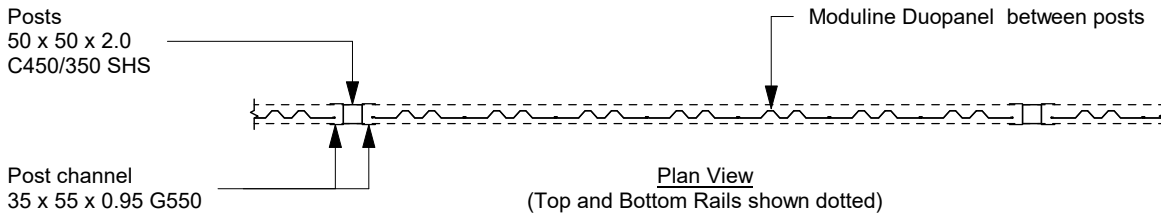

**Notes:**  
All measurements in mm unless stated otherwise.

**1.5m high solid panel type - Type 4**  
(See specification sheet for detail)

(Scale 1:20)

A	04/09/2024
-	20/09/2019
Revision	Date

Revision	A
----------	---



# PRODUCER STATEMENT - PS1 - DESIGN

ENG REF: 7327 Type 4e

ISSUED BY Anthony Marino (for Marino Consultants and Associates Ltd)  
(Design Firm)

TO: Metal Rollforming Ltd  
(Owner/Developer)

TO BE SUPPLIED TO: Various  
(Building Consent Authority)

IN RESPECT OF: Moduline SafeBarrier Pro 1.5m high - Type 4e  
(Description of Building Work)

AT: Non-Specific,  
(Address)

LOT: \_\_\_\_\_ DP: \_\_\_\_\_ SO: \_\_\_\_\_

We have been engaged by the owner/developer referred to above to provide specific structural design services in respect of the requirements of Clause(s) B1, F4, F9 of the Building Code for

- All or  Part only (as specified in the attachment to this statement, ref: 7327 Type 4e ), of the proposed building work.

The design carried out by us has been prepared in accordance with:

- Compliance Documents issued by the Ministry of Business, Innovation and Employment B1/VM1 (NZS3603, AS/NZS1170, NZS3404), F4/AS1, F9/AS1

- Alternative solution as per the attached schedule \_\_\_\_\_

The proposed building work covered by this producer statement is described on the drawings titled

Moduline SafeBarrier Pro 1.5m high - Type 4e and numbered 1, 2, 3, 4

together with the specification, and other documents set out in the schedule attached to this statement.

On behalf of the Design Firm, and subject to:

- (i) Site verification of the following design assumptions:  
Strength of supporting structure by others
- (ii) All proprietary products meeting their performance specification requirements;

I believe on reasonable grounds that a) the building, if constructed in accordance with the drawings, specifications, and other documents provided or listed in the attached schedule, will comply with the relevant provisions of the Building Code and that b) the persons who have undertaken the design have the necessary competency to do so. I also recommend the following level of construction monitoring/observation:

- Not required (observation by Council)

I, Anthony Lewis Marino am CPEng No 69890

I am a member of Engineering New Zealand and hold the following qualifications: BEHons., CPEng.

The Design Firm issuing this statement holds a current policy of Professional Indemnity Insurance no less than \$200,000.

The Design Firm is a member of ACENZ:

SIGNED BY Anthony Marino (B.E.(hons), CPEng (Civil and Structural), CMEngNZ, SESOC)

ON BEHALF OF Marino Consultants and Associates Ltd.

Anthony Marino DATE 19/09/2024

57 Stace Hopper Drive, One Tree Point 0118  
(021) 518 171 (Mobile)  
anthony.marino@outlook.co.nz (Email)

Note: This statement shall only be relied upon by the Building Consent Authority named above. Liability under this statement accrues to the Design Firm only. The total maximum amount of damages payable arising from this statement and all other statements provided to the Building Consent Authority in relation to this building work, whether in contract, tort or otherwise (including negligence), is limited to \$200,000

This form is to accompany Form 2 of the Building (Forms) Regulations 2004 for the application of a Building Consent.